

TABULATED DATA

STEEL MANHOLE SHIELDS

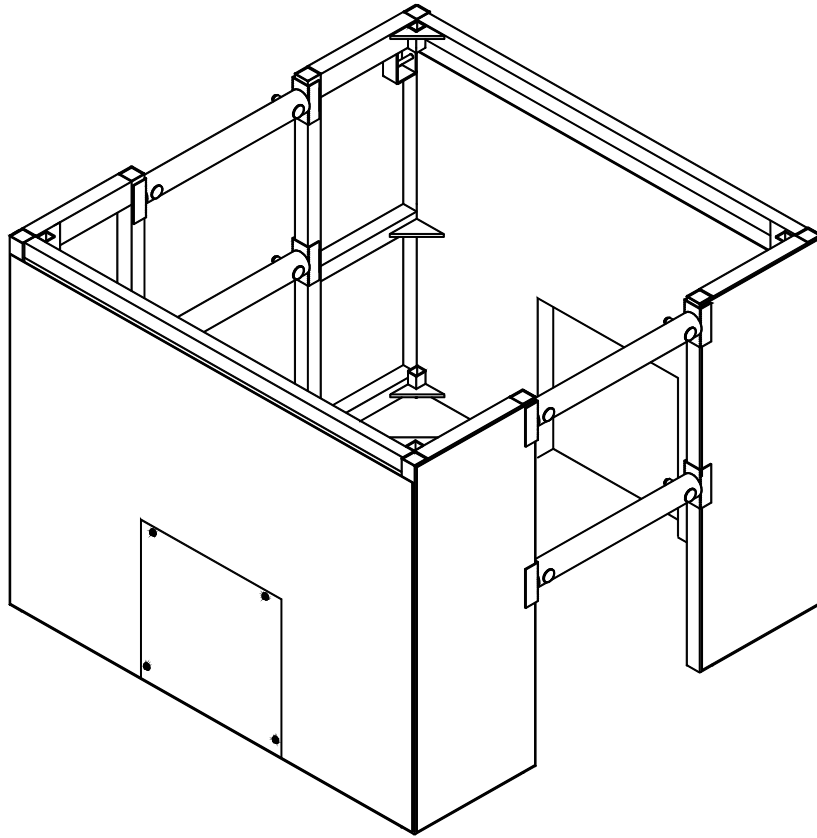

SPEED  **SHORE**[®]

3330 S. SAM HOUSTON PKWY E. HOUSTON, TEXAS 77047
Phone: 713.943.0750 ■ Toll Free: 800.231.6662 ■ Fax: 713. 943.8483

© COPYRIGHT, U.S.A., SPEED SHORE CORPORATION, 2009

WARNING

EXCAVATION PROCEDURES MAY BE VERY DANGEROUS

- A TRAINED *COMPETENT PERSON* SHALL: SUPERVISE ALL EXCAVATION OPERATIONS, ENSURE THAT ALL PERSONNEL ARE WORKING IN SAFE CONDITIONS, AND HAVE THOROUGH KNOWLEDGE OF THIS TABULATED DATA. THE *COMPETENT PERSON* SHALL HAVE THE AUTHORITY TO STOP WORK WHEN IT IS UNSAFE FOR WORKERS TO ENTER AN EXCAVATION.
- ALL PERSONNEL SHALL BE TRAINED IN CORRECT EXCAVATION PROCEDURES, PROPER USE OF THE PROTECTIVE SYSTEM AND ALL SAFETY PRECAUTIONS.
- EXCAVATIONS AND PROTECTIVE SYSTEMS SHALL BE INSPECTED AT LEAST DAILY AND WHENEVER THERE IS A CHANGE OF SOIL, WATER OR OTHER JOB SITE CONDITIONS.
- ALL LIFTING AND PULLING EQUIPMENT, INCLUDING CABLES, SLINGS, CHAINS, SHACKLES AND SAFETY HOOKS SHALL BE EVALUATED FOR SUITABILITY AND CAPACITY, AND SHALL BE INSPECTED FOR DAMAGE OR DEFECTS PRIOR TO USE.
- ALL INSTALLATION AND REMOVAL OF SHORING AND SHIELDING SHALL BE FROM ABOVE GROUND ONLY.
- DO NOT ALLOW PERSONNEL TO ENTER AN EXCAVATION THAT IS NOT PROPERLY SHORED, SHIELDED OR SLOPED.
- PERSONNEL SHALL ALWAYS WORK WITHIN THE SHORING AND SHIELDING. PERSONNEL SHALL NOT STAND ON THE EDGE OF AN UNSHORED EXCAVATION.
- ALL PERSONNEL SHALL ENTER AND EXIT EXCAVATIONS ONLY WITHIN SHIELDED OR SHORED AREAS.

SPEED SHORE'S "MANUFACTURER'S TABULATED DATA" IS A GENERAL SET OF GUIDELINES AND TABLES TO ASSIST THE *COMPETENT PERSON* IN SELECTING A SAFETY SYSTEM AND THE PROPER SHORING OR SHIELDING EQUIPMENT. THE *COMPETENT PERSON* HAS SOLE RESPONSIBILITY FOR JOB SITE SAFETY AND THE PROPER SELECTION AND INSTALLATION AND REMOVAL OF THE SHORING OR SHIELDING EQUIPMENT.

THIS TABULATED DATA IS NOT INTENDED TO BE USED AS A JOB SPECIFIC EXCAVATION SAFETY PLAN, BUT SHALL BE USED BY THE *COMPETENT PERSON* TO SUPPLEMENT HIS TRAINING, HIS EXPERIENCE AND HIS KNOWLEDGE OF THE JOB CONDITIONS AND SOIL TYPE.



SPEED SHORE
TABULATED DATA

1.0 SCOPE

- 1.1 Speed Shore's Tabulated Data complies with the O.S.H.A. standards as stated in the Code of Federal Regulations 29, Part 1926, Subpart P - Excavations, Section 1926.652(c)(2). This data shall only be used by the contractor's *competent person* in the selection of Speed Shore Trench Shields. The *competent person* shall be experienced and knowledgeable in trenching and excavation procedures, soil identification and in the use of Speed Shore Trench Shields.
- 1.2 All personnel involved in the installation, removal and use of Trench Shields shall be trained in their use and advised of appropriate safety procedures.
- 1.3 Table MHS-1 is based upon requirements stated in CFR 29, Part 1926 and applicable portions of CFR 29, Part 1910. The *competent person* shall know and understand the requirements of those parts before using this data.
- 1.4 Whenever there is a variance between this Tabulated Data and CFR 29, Part 1926, Subpart P - Excavations, this Tabulated Data shall take precedence. Whenever a topic or subject is not contained in this Tabulated Data, the *competent person* shall refer to CFR 29, Part 1926, Subpart P - Excavations.
- 1.5 This data refers to the Code of Federal Regulations, 29, Parts 1910 and 1926. In states that have their own state O.S.H.A. refer to similar regulations in the current construction rules published by the state office of Occupational Health and Safety.
- 1.6 Table MHS-1 shall be used only in excavations with soil conditions as noted. For other soil and excavation conditions and depths, site-specific engineered designs are required. Contact Speed Shore Corporation for assistance.
- 1.7 This Tabulated Data is applicable for standard products manufactured exclusively by Speed Shore and may only be used with Speed Shore manufactured products. Any modification of Speed Shore products not specifically authorized by Speed Shore Corporation voids this data.

2.0 DEFINITIONS (RE: CFR 29, Part 1926.32 Definitions) - RESTATED FOR EMPHASIS

- 2.1 1926.32 (F) "*competent person*" means one who is capable of identifying existing and predictable hazards in the surroundings or working conditions which are unsanitary, hazardous or dangerous to employees; and who has authorization to take prompt corrective measures to eliminate them.
- 2.2 1926.32 (p) "Shall" means mandatory.

3.0 SOIL CLASSIFICATIONS

- 3.1 In order to use the data presented in Table MHS-1, the soil type, or types, in which the excavation is cut shall first be determined by the *competent person* according to the O.S.H.A. soil classifications as set forth in CFR 29, Part 1926, Subpart P, Appendix A.
- 3.2 Table MHS-1 is also for use in Type C-60 soil (see 3.3 for definition).
- 3.3 Type C-60 soil is a moist, cohesive soil or a moist dense granular soil which does not fit into Type A or Type B classifications, and is not flowing or submerged. This material can be cut with near vertical sidewalls and will stand unsupported long enough to allow the shields to be properly installed. The *competent person* must monitor the excavation for signs of deterioration of the soil as indicated by, but not limited to, freely seeping water or flowing soil entering the excavation around or below the Trench Shield. An alternate design for less stable Type C soil may be required where there is evidence of deterioration.



- 3.4 Water flowing into an excavation, from either above or below ground, will cause a decrease in the stability of the soil. Therefore, the *competent person* shall take action to prevent water from entering the excavation and promptly remove any water that accumulates in the excavation. Closer monitoring of the soil is required under wet conditions, particularly in the less cohesive (weaker) soil conditions. A small amount of water, or flowing conditions may downgrade the soil classification to a less stable classification. A large amount of water, or flowing conditions will downgrade all soils to O.S.H.A. Type C. Speed Shore shoring and shielding systems may be used safely in wet conditions when the excavation is monitored by the *competent person*. Example: When repairing a leak in utility lines, it is often difficult or even impossible to keep water out of the excavation.

4.0 PRESENTATION OF INFORMATION

- 4.1 Information is presented in tabular form in Table MHS-1 is for use in O.S.H.A. Type A, B and C soils, and for use in Type C-60 soil (see 3.3 for definition).
- 4.2 Table MHS-1 is not considered adequate when loads imposed by structures or by stored material adjacent to the trench weigh in excess of the load imposed by 3 feet of soil surcharge. The term "adjacent" as used here means the area within a horizontal distance from the edge of the trench equal to the depth of the trench.
- 4.3 Using Table MHS-1 after determining the soil type, the *competent person* determines the maximum depth the Manhole Shield may be used.

5.0 ASSEMBLY

- 5.1 Shields shall be inspected by a *competent person* before and after assembly.
- 5.2 All damage shall be evaluated and repairs made under the direction of a registered professional engineer. All missing or damaged components shall be replaced with genuine Speed Shore parts.
- 5.3 All lifting and pulling equipment, (including cables, slings, chains, shackles and safety hooks) used to handle shields or components shall be evaluated for lifting capacity, and inspected for damage or defects, prior to use, by experienced operators and shall meet O.S.H.A. requirements.
- 5.4 Tag lines or other approved safety devices shall be utilized to keep employees away from loads handled by lifting equipment.
- 5.5 Spreaders, pins with keepers and accessories shall be in place before using the shields.
- 5.6 Standard Spreader Requirements is limited to 5" schedule 80 pipe, maximum length of 4'.
- 5.7 Two spreaders are required at each end of all shields.
- 5.8 All spreaders shall be singled or doubled pinned at each end, based on number of holes in the spreader sockets, with 1.5-inch diameter pins furnished by Speed Shore.
- 5.9 Assembly instructions:
- 5.9.1 Lay first panel on ground, spreader sockets up.
 - 5.9.2 Stand spreaders over sockets and insert pins with keepers.
 - 5.9.3 Lower second panel onto spreader tubes and insert pins with keepers.
 - 5.9.4 Attach 4-point lifting sling to lifting brackets.
 - 5.9.5 Stand shield up, attach tag lines and install into trench properly.
- 5.10 Manhole Shields may be stacked utilizing stacking socket and appurtenances providing the allowable designed depth rating for each shield is not exceeded in the Table MHS-1.
- 5.11 All replaceable cutouts in the Manhole Shields shall be filled with Speed Shore supplied cover panels when the block-outs are not being used.



6.0 INSPECTION

- 6.1 The *competent person* must evaluate the soils to assure the rated capacity of the Manhole Shields is not exceeded by the lateral pressure of the soil. Soils shall be evaluated in accordance with Part 3.0.
- 6.2 The *competent person* shall monitor all phases of the assembly, installation and use of this product to evaluate and eliminate methods, which could endanger employees utilizing this product.
- 6.3 Daily inspections of the Manhole Shield and accessories must be performed by the *competent person* and deficiencies corrected.
- 6.4 Inspections shall be conducted as necessary for hazards associated with: water accumulation, changing soil conditions, or changing site weather conditions.
- 6.5 Stacked shields shall be monitored to assure that each panel is secured to the one below it.

7.0 SAFETY SPECIFICATIONS

- 7.1 Employees shall be protected from loose or falling material. Manhole Shields must always be used in a manner that loose or falling soil cannot enter over the top or through the end of the shield. End plates may be required. Spoil piles must be kept back from the edge of the excavation at least 2 feet.
- 7.2 Employees shall not enter or exit shields through unprotected areas and shall remain in shields at all times while working.
- 7.3 Employees shall not be in or under a shield while it is being lifted or moved.
- 7.4 Bottom of shields may be a maximum of 2 feet above the bottom of the trench if there are no signs of deterioration of the trench face below or at the end of the shield.
- 7.5 Use of the spreader system for any purpose other than support for the sidewall panels is prohibited without written permission from the manufacturer.
- 7.6 The sides of the excavation should be cut vertical and narrow to prevent lateral movement of the shield. The width of the excavation shall be no wider than the width of the shield plus 12 inches. If soil conditions do not allow the sides of the excavation to be cut vertical and narrow, the competent person shall install the shield in a safe manner to restrict lateral movement or other hazardous movement of the shield in the event of the application of sudden lateral loads. The competent person shall make the final determination to ensure lateral movement of the shield has been controlled.
- 7.7 Water shall be prevented from entering the excavation and any water that does accumulate in the excavation shall be pumped out.
- 7.8 Contact Speed Shore for any non-typical use of the Manhole Shield.

8.0 EXAMPLE TO ILLUSTRATE THE USE OF TABLE MHS-1:

Problem: A precast manhole 8' diameter is being set 16' deep in soil that has been classified by the *competent person* to be O.S.H.A. Type C soil. Stacking 2 identical 8 feet high Manhole shields is desired. Which Manhole Shields may be used?

Studying Table MHS-1 shows that a MHS-0812-DW is adequate down to 30 feet deep in C-80 soil. Further down the table is a MHS-0812-DW-RC is adequate down to 21 feet in C-80 soil. Either of these 2 shields may be used.



TABLE MHS-1

**"MHS" MODELS
DOUBLE SKIN PLATE WALLS**

MODEL	CAPACITY P.S.F.	MAXIMUM DEPTH RATING FOR SOIL TYPES FEET					VERTICAL PIPE CLEARANCE INCHES	WEIGHT APPX. POUNDS
		A-25	B-35	B-45	C-60	C-80		
4" SINGLE WALL								
MHS-0408-SW	2027	50	50	45	35	26	22"	2350
MHS-0410-SW	1275	50	36	29	22	17	22"	2850
MHS-0412-SW	875	34	25	20	15	12	22"	3500
MHS-0808-SW	1641	50	49	39	30	24	45"	3625
MHS-0810-SW	1032	42	31	25	20	16	45"	4650
MHS-0812-SW	708	29	22	18	15	12	45"	5245
4" DOUBLE WALL								
MHS-0408-DW	5159	50	50	50	50	50	22"	2450
MHS-0410-DW	3245	50	50	50	50	42	22"	3575
MHS-0412-DW	2228	50	50	50	38	29	22"	4200
MHS-0808-DW	5055	50	50	50	50	50	45"	4170
MHS-0810-DW	3180	50	50	50	50	43	45"	5450
MHS-0812-DW	2183	50	50	50	39	30	45"	6500
4" DOUBLE WALL with Cut-Outs								
MHS-0808-DW-RC	3800	50	50	50	50	50	45"	4580
MHS-0810-DW-RC	2238	50	50	50	40	31	45"	5440
MHS-0812-DW-RC	1465	50	44	35	27	21	45"	6475

- (1) If a specific model Manhole shield is not shown in Table MHS-1, the competent person must refer to the Manhole shield certification to determine capacity and working depths. All other aspects of this tabulated data will apply to any Manhole shield not shown in Tables MHS-1.
- (2) Weights are approximate.
- (3) Standard spreader sizes for Manhole trench shields as shown in Table MHS-1 is limited to 5" schedule 80 pipe, maximum length of 4'.
- (4) Sidewall wings dimensions as follow:
 - a. 2' long on 8' wide Manhole Shields.
 - b. 3' long on 10' wide Manhole Shields.
 - c. 4' long on 12' wide Manhole Shields.

