

TABULATED DATA

"STEEL-FRAMED" ALUMINUM PANEL

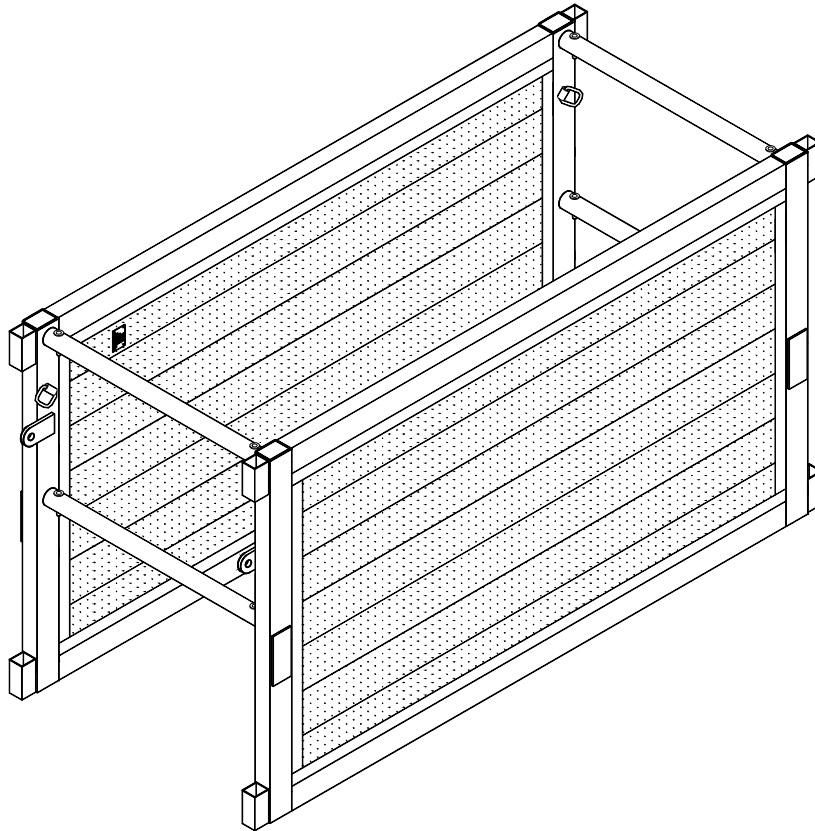

SPEED  SHORE®

3330 S. SAM HOUSTON PKWY E. HOUSTON, TEXAS 77047
Phone: 713.943.0750 ■ Toll Free: 800.231.6662 ■ Fax: 713.943.8483

© COPYRIGHT, U.S.A., SPEED SHORE CORPORATION, 2009

WARNING

EXCAVATION PROCEDURES MAY BE VERY DANGEROUS

- A TRAINED *COMPETENT PERSON* SHALL: SUPERVISE ALL EXCAVATION OPERATIONS, ENSURE THAT ALL PERSONNEL ARE WORKING IN SAFE CONDITIONS, AND HAVE THOROUGH KNOWLEDGE OF THIS TABULATED DATA. THE *COMPETENT PERSON* SHALL HAVE THE AUTHORITY TO STOP WORK WHEN IT IS UNSAFE FOR WORKERS TO ENTER AN EXCAVATION.
- ALL PERSONNEL SHALL BE TRAINED IN CORRECT EXCAVATION PROCEDURES, PROPER USE OF THE PROTECTIVE SYSTEM AND ALL SAFETY PRECAUTIONS.
- EXCAVATIONS AND PROTECTIVE SYSTEMS SHALL BE INSPECTED AT LEAST DAILY AND WHENEVER THERE IS A CHANGE OF SOIL, WATER OR OTHER JOB SITE CONDITIONS.
- ALL LIFTING AND PULLING EQUIPMENT, INCLUDING CABLES, SLINGS, CHAINS, SHACKLES AND SAFETY HOOKS SHALL BE EVALUATED FOR SUITABILITY AND CAPACITY, AND SHALL BE INSPECTED FOR DAMAGE OR DEFECTS PRIOR TO USE.
- ALL INSTALLATION AND REMOVAL OF SHORING AND SHIELDING SHALL BE FROM ABOVE GROUND ONLY.
- DO NOT ALLOW PERSONNEL TO ENTER AN EXCAVATION THAT IS NOT PROPERLY SHORED, SHIELDED OR SLOPED.
- PERSONNEL SHALL ALWAYS WORK WITHIN THE SHORING AND SHIELDING. PERSONNEL SHALL NOT STAND ON THE EDGE OF AN UNSHORED EXCAVATION.
- ALL PERSONNEL SHALL ENTER AND EXIT EXCAVATIONS ONLY WITHIN SHIELDED OR SHORED AREAS.

SPEED SHORE'S "MANUFACTURER'S TABULATED DATA" IS A GENERAL SET OF GUIDELINES AND TABLES TO ASSIST THE *COMPETENT PERSON* IN SELECTING A SAFETY SYSTEM AND THE PROPER SHORING OR SHIELDING EQUIPMENT. THE *COMPETENT PERSON* HAS SOLE RESPONSIBILITY FOR JOB SITE SAFETY AND THE PROPER SELECTION AND INSTALLATION AND REMOVAL OF THE SHORING OR SHIELDING EQUIPMENT.

THIS TABULATED DATA IS NOT INTENDED TO BE USED AS A JOB SPECIFIC EXCAVATION SAFETY PLAN, BUT SHALL BE USED BY THE *COMPETENT PERSON* TO SUPPLEMENT HIS TRAINING, HIS EXPERIENCE AND HIS KNOWLEDGE OF THE JOB CONDITIONS AND SOIL TYPE.



SPEED SHORE
TABULATED DATA

1.0 SCOPE

- 1.1 Speed Shore's Tabulated Data complies with the O.S.H.A. standards as stated in the Code of Federal Regulations 29, Part 1926, Subpart P - Excavations, Section 1926.652(c)(2). This data shall only be used by the contractor's *competent person* in the selection of Speed Shore Trench Shields. The *competent person* shall be experienced and knowledgeable in trenching and excavation procedures, soil identification and in the use of Speed Shore "Steel Framed" Aluminum Panel Shields.
- 1.2 All personnel involved in the installation, removal and use of "Steel Framed" Aluminum Panel Shields shall be trained in their use and advised of appropriate safety procedures.
- 1.3 Table SF-APS-1 is based upon requirements stated in CFR 29, Part 1926 and applicable portions of CFR 29, Part 1910. The *competent person* shall know and understand the requirements of those parts before using this data.
- 1.4 Whenever there is a variance between this Tabulated Data and CFR 29, Part 1926, Subpart P - Excavations, this Tabulated Data shall take precedence. Whenever a topic or subject is not contained in this Tabulated Data, the *competent person* shall refer to CFR 29, Part 1926, Subpart P - Excavations.
- 1.5 This data refers to the Code of Federal Regulations, 29, Parts 1910 and 1926. In states that have their own state O.S.H.A. refer to similar regulations in the current construction rules published by the state office of Occupational Health and Safety.
- 1.6 Table SF-APS-1 shall be used only in excavations with soil conditions as noted. For other soil and excavation conditions and depths, site-specific engineered designs are required. Contact Speed Shore Corporation for assistance
- 1.7 This Tabulated Data is applicable for standard products manufactured exclusively by Speed Shore and may only be used with Speed Shore manufactured products. Any modification of Speed Shore products not specifically authorized by Speed Shore Corporation voids this data.

2.0 DEFINITIONS (RE: CFR 29, Part 1926.32 Definitions) - RESTATED FOR EMPHASIS

- 2.1 1926.32 (F) "competent person" means one who is capable of identifying existing and predictable hazards in the surroundings or working conditions which are unsanitary, hazardous or dangerous to employees; and who has authorization to take prompt corrective measures to eliminate them.
- 2.2 1926.32 (p) "Shall" means mandatory.

3.0 SOIL CLASSIFICATIONS

- 3.1 In order to use the data presented in Table SF-APS-1 the soil type, or types, in which the excavation is cut shall first be determined by the *competent person* according to the O.S.H.A. soil classifications as set forth in CFR 29, Part 1926, Subpart P, Appendix A.
- 3.2 Table SF-APS-1 is also for use in Type C-60 soil (see 3.3 for definition).
- 3.3 Type C-60 soil is a moist, cohesive soil or a moist dense granular soil, which does not fit into Type A or Type B classifications, and is not flowing or submerged. This material can be cut with near vertical sidewalls and will stand unsupported long enough to allow the shields to be properly installed. The *competent person* must monitor the excavation for signs of deterioration of the soil as indicated by, but not limited to, freely seeping water or flowing soil entering the excavation around or below the Trench Shield. An alternate design for less stable Type C soil may be required where there is evidence of deterioration.



- 3.4 Water flowing into an excavation, from either above or below ground, will cause a decrease in the stability of the soil. Therefore, the **competent person** shall take action to prevent water from entering the excavation and promptly remove any water that accumulates in the excavation. Closer monitoring of the soil is required under wet conditions, particularly in the less cohesive (weaker) soil conditions. A small amount of water, or flowing conditions may downgrade the soil classification to a less stable classification. A large amount of water, or flowing conditions will downgrade all soils to O.S.H.A. Type C. Speed Shore shoring and shielding systems may be used safely in wet conditions when the excavation is monitored by the **competent person**. Example: When repairing a leak in utility lines, it is often difficult or even impossible to keep water out of the excavation.

4.0 PRESENTATION OF INFORMATION

- 4.1 Information is presented in tabular form in Table SF-APS-1 for use in O.S.H.A. Type A, B and C soils, and for use in Type C-60 soil (see 3.3 for definition).
- 4.2 Table SF-APS-1 is not considered adequate when loads imposed by structures or by stored material adjacent to the trench weigh in excess of the load imposed by 3 feet of soil surcharge. The term "adjacent" as used here means the area within a horizontal distance from the edge of the trench equal to the depth of the trench.
- 4.3 Using Table SF-APS-1 the **competent person** determines the maximum depth the "Steel Framed" Aluminum Panel Shields may be used.

5.0 ASSEMBLY

- 5.1 "Steel Framed" Aluminum Panel Shields shall be inspected by a **competent person** before assembly.
- 5.2 All damage shall be evaluated and repairs made under the direction of a registered professional engineer. All missing or damaged components shall be replaced with genuine Speed Shore parts.
- 5.3 All lifting and pulling equipment, (including cables, slings, chains, shackles and safety hooks) used to handle shields or components shall be evaluated for lifting capacity, and inspected for damage or defects, prior to use, by experienced operators and shall meet O.S.H.A. requirements.
- 5.4 Tag lines or other approved safety devices shall be utilized to keep employees away from loads handled by lifting equipment.
- 5.5 Spreaders, pins with keepers and accessories shall be in place before using the "Steel Framed" Aluminum Panel Shields.
- 5.6 Two spreaders are required at each end of all shields.
- 5.7 All spreaders shall be pinned at each end with 1.5-inch diameter pins furnished by Speed Shore.
- 5.8 Assembly instructions:
- 5.8.1 Lay the first panel on ground, spreader sockets up.
 - 5.8.2 Stand spreaders over sockets and insert pins with keepers.
 - 5.8.3 Lower second panel onto spreader tubes and insert pins with keepers.
 - 5.8.4 Attach 4-point lifting sling to lifting brackets.
 - 5.8.5 Stand "SF" APS shield up, attach tag lines and install into trench properly.

6.0 INSPECTION

- 6.1 The competent person must evaluate the soils to assure the rated capacity of the "Steel Framed" Aluminum Panel Shields is not exceeded by the lateral pressure of the soil. Soils shall be evaluated in accordance with Part 3.0.
- 6.2 The **competent person** shall monitor all phases of the assembly, installation and use of this product to evaluate and eliminate methods, which could endanger employees utilizing this product.



- 6.3 Daily inspections of the "Steel Framed" Aluminum Panel Shields and accessories must be performed by the **competent person** and deficiencies corrected.
- 6.4 Inspections shall be conducted as necessary for hazards associated with: water accumulation, changing soil conditions, or changing site weather conditions.
- 6.5 Stacked shields shall be monitored to assure that each panel is secured to the one below it. Four feet high stacking shields (those with only 2 spreaders) shall not be used as the bottom shield.

7.0 SAFETY SPECIFICATIONS

- 7.1 Employees shall be protected from loose or falling material. "Steel Framed" Aluminum Panel Shields must always be used in a manner that loose or falling soil cannot enter over the top or through the end of the shield. End plates may be required. Spoil piles must be kept back from the edge of the excavation at least 2 feet.
- 7.2 Employees shall not enter or exit shields through unprotected areas and shall remain in shields at all times while working.
- 7.3 Employees shall not be in or under a shield while it is being lifted or moved.
- 7.4 Bottom of shields may be a maximum of 2 feet above the bottom of the trench if there are no signs of deterioration of the trench face below or at the end of the shield.
- 7.5 Use of the spreader system for any purpose other than support for the sidewall panels is prohibited without written permission from the manufacturer.
- 7.6 The sides of the excavation should be cut vertical and narrow to prevent lateral movement of the shield. The width of the excavation shall be no wider than the width of the shield plus 12 inches. If soil conditions do not allow the sides of the excavation to be cut vertical and narrow, the competent person shall install the shield in a safe manner to restrict lateral movement or other hazardous movement of the shield in the event of the application of sudden lateral loads. The competent person shall make the final determination to ensure lateral movement of the shield has been controlled.
- 7.7 Use Speed Shore supplied standard spreaders.
- 7.8 Water shall be prevented from entering the excavation and any water that does accumulate in the excavation shall be pumped out.
- 7.9 Contact Speed Shore for any non-typical use of the "Steel Framed" Aluminum Panel Shields.

8.0 EXAMPLE TO ILLUSTRATE THE USE OF TABLE SF-APS-1:

Problem: A trench is 8 feet deep in soil that has been classified by the **competent person** to be O.S.H.A. Type B. For pipe joint purposes, 16 feet long shields are required. Which "Steel Framed" Aluminum Panel Shields may be used?

Studying Table SF-APS-1 shows that a APS-SF-0816 is adequate down to 12 feet.



TABLE SF-APS-1

MODEL	CAPACITY P.S.F.	MAXIMUM DEPTH RATING FOR SPOIL TYPE (FEET)				VERTICAL PIPE CLEARANCE INCHES	WEIGHT APPX. POUNDS
		A-25	B-45	C-60	C-80		
APS-SF-0406	2,605	50	50	44	34	22	970
APS-SF-0408	1,869	50	42	32	24	22	1,176
APS-SF-0410	1,165	46	26	20	16	22	1,380
APS-SF-0412	795	31	18	14	11	22	1,584
APS-SF-0414	577	22	13	10	8	22	1,790
APS-SF-0416	438	17	10	8	7	22	1,994
APS-SF-0606	1,296	50	30	23	18	36	1,202
APS-SF-0608	972	39	23	18	14	36	1,460
APS-SF-0610	777	31	19	15	12	36	1,720
APS-SF-0612	648	26	16	13	10	36	1,980
APS-SF-0614	555	22	14	11	9	36	2,240
APS-SF-0616	438	18	11	9	8	36	2,498
APS-SF-0806	1150	47	28	22	17	43	1,432
APS-SF-0808	862	36	22	17	14	43	1,746
APS-SF-0810	690	29	18	14	12	43	2,060
APS-SF-0812	575	24	15	12	10	43	2,374
APS-SF-0814	493	21	13	11	9	43	2,690
APS-SF-0816	431	18	12	10	8	43	3,004

Notes

- (1) If a specific model "SF" APS trench shield is not shown in Table SF-APS-1, the competent person must refer to the trench shield certification to determine capacity and working depths. All other aspects of this tabulated data applies to any "SF" APS shield not shown in Table SF-APS-1.
- (2) Weights are approximate.
- (3) Standard spreader sizes for "SF" APS shields are 5" schedule 80 pipes, maximum length of 12'. Spreader materials shall conform to ASTM A501 or ASTM A53, Type E or S, grade B.

